

SAJ Series

SAJ12-150 12V150Ah

SAJ series battery uses AGM and gel mixed technology. It has good cycle life and large current discharge performance. It is a cost effective product and can be widely used in different photovoltaic, lighting, power supply and control systems..

Benefits

- General Purpose according to EUROBAT Classification
- Special AGM separator, adding gel electrolyte, shallow cycle life is long
- Maximum charge efficiency
- High gas recombination efficiency
- Low self-discharge rate
- Horizontal or Vertical installization
- Easy installation and handling

Drawing

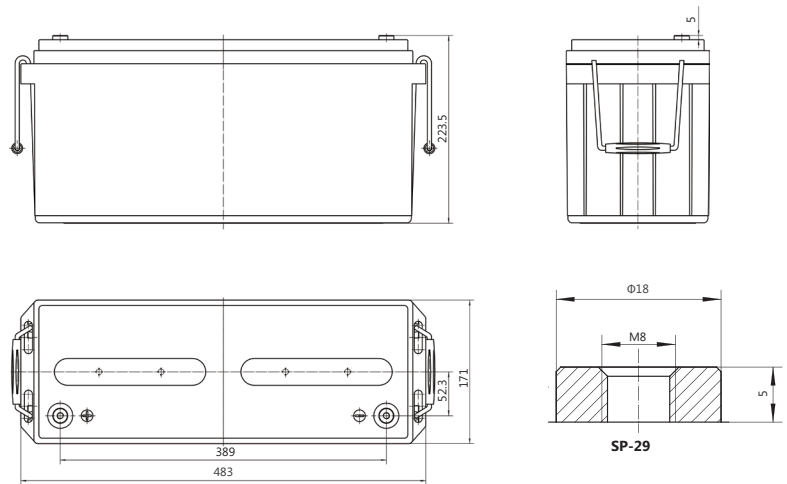

Applications

- Solar (Wind) energy system
- Solar communication/station
- Mobile storage system

Standards

- IEC 60896-21/22
- DIN 43539-T5
- EUROBAT guide

Specifications

Battery Model	SAJ12-150			
Design Life (years, 25°C)	10			
Capacity (Ah, 25°C)	10HR (15A, 1.80V)	5HR (24.9A, 1.80V)	3HR (36.75A, 1.80V)	1HR (81.3A, 1.75V)
	150	124.5	110.25	81.3
Dimensions (mm)	Length	Width	Height	Total Height
	483	171	218.5	223.5
Approx. Weight (kg)	41.5			
Reference Internal Resistance (mΩ)	3.6 ±15% (full charged @ 25 °C ,testing device:HIOKI BT3562)			
Maximum Discharge Current (A/5 Sec.)	1200			
Self-Discharge (25°C)	≤ 1.5% per months			
Charge Voltage (V/cell, 25°C)	Cycle use		Float use	
	2.40(-3.5mV/°C/cell), max charge current: 30A		2.27(-3.5mV/°C/cell)	
Short Circuit Current (A)	3300			

Discharge Data

Constant Current Discharge Data (25°C, A)									
End Voltage (V/cell)	h								
	1	3	5	10	20	50	100	120	240
1.70	83.55	38.70	26.18	15.35	7.850	3.330	1.740	1.470	0.780
1.75	81.30	37.95	25.65	15.20	7.725	3.270	1.710	1.449	0.765
1.80	78.75	36.75	24.90	15.00	7.600	3.195	1.680	1.425	0.750
1.85	75.75	35.40	24.00	14.70	7.450	3.105	1.635	1.389	0.735
1.90	72.00	33.75	22.95	14.30	7.250	3.000	1.590	1.350	0.720

Constant Power Discharge Data (25°C, W/cell)									
End Voltage (V/cell)	h								
	1	3	5	10	20	50	100	120	240
1.70	150.5	63.20	45.50	28.30	14.70	7.130	3.850	3.270	1.650
1.75	145.50	62.10	44.40	28.00	14.45	7.050	3.670	3.210	1.620
1.80	141.50	61.10	43.20	27.70	14.20	6.750	3.420	3.090	1.590
1.85	137.00	60.30	42.20	27.10	13.90	6.390	3.250	2.890	1.530
1.90	133.20	59.40	41.00	26.70	13.70	6.150	3.110	2.790	1.500

Performance Curve

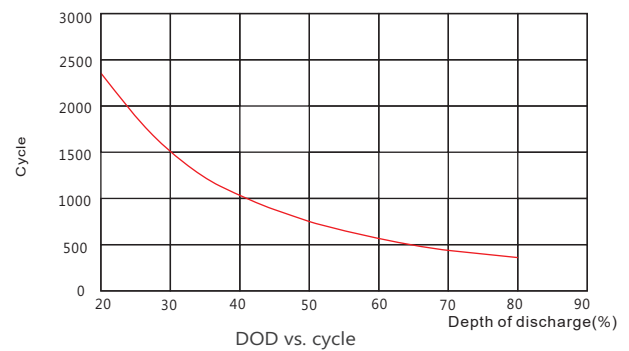
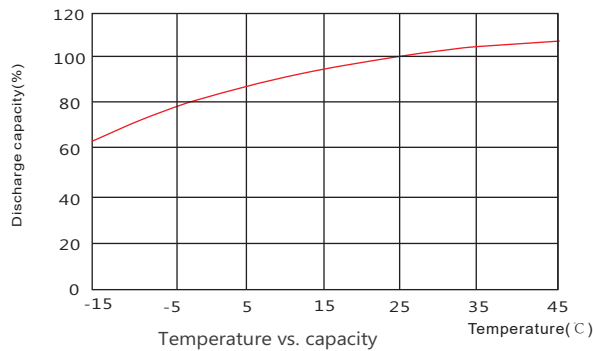
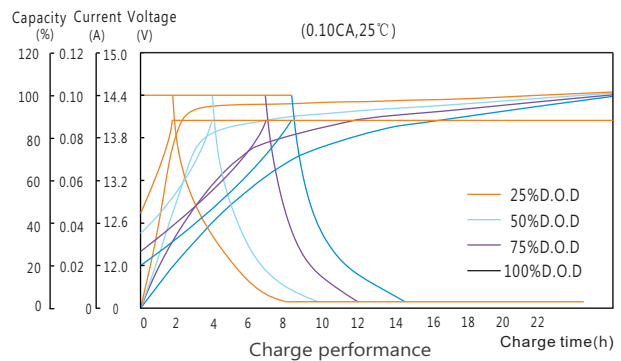
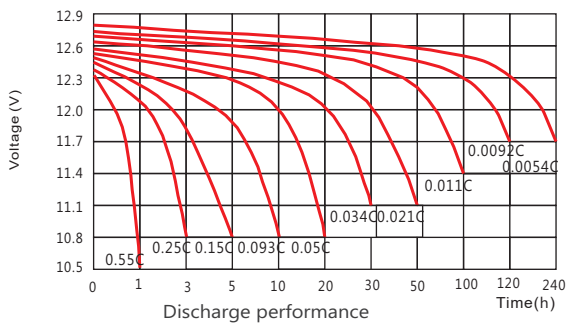

Sacred Sun Power Sources Co., Ltd.

Add: No.1 Shengyang Road, Qufu 273100 PRC
Tel: +86-537-4422313 Fax: +86-537-4411980
Email: sales@sacredsunsun.cn

Sacred Sun Hong Kong Co., Limited

Add: RM 19C Lockhart CTR 301-307 Lockhart RD Wan Chai, Hong Kong
Email: admin.hk@sacredsunsun.hk

Sacred Sun Asia Pacific Pte Ltd.

Add: 1 Ubi View, #04-12, Focus One, Singapore 408555
Email: admin.sg@sacredsunsun.sg

Sacred Sun Europe SARL

Add: ZAE Fontaine, 33210 Fargues, France
Email: admin.eu@sacredsunsun.eu

Sacred Sun MEA FZE

Add: No. 311 office, Building LOB 14, JAFZA, Dubai, UAE
Email: admin.ae@sacredsunsun.ae

